

CLH-L2C models

FLUSH MOUNT MAGNETIC CONTACTS



CLH-L2C



Magnetic contact Flying lead

CLH-L2 models offer the highest security available on the market today, protecting from attacks that come both from the inside or the outside of the controlled perimeter. In fact, while traditional triple-balanced contacts can be disabled from the inside by inserting simple magnetic blades between the sensor and the magnet, Magnasphere® L2 models are the only passive magnetic contacts that can protect from insider attacks. CLH-L2C models offer the highest security in a compact, flush-mount case that can be installed with a simple 25mm iron drill bit on any door or window.

- Plastic and brass case
- Protection from insider attacks
- High resistance to mechanical and electrical shocks
- Fully potted construction: suitable for internal or external use

TECHNICAL FEATURES

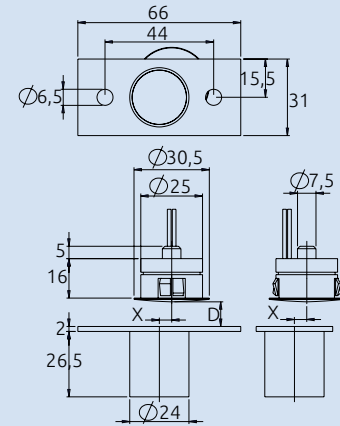

CASE
Plastic and brass

MAGNET
Neodymium

POTTING
Fully potted

ELECTRICAL CONTACT
Closed with magnet in secure position

ELECTRICAL PARAMETERS
30 VDC max, 250 mA, 0.25 W

TERMINALS
30cm 4x0.33 flying lead, tamper pass-through

RESISTANCE TO MECHANICAL SHOCKS
Up to 100g acceleration

SECURITY
Compatible w/ Grade 3 EN 50131-2-6

ENVIRONMENTAL CLASS
Compatible w/ Class IV EN 50131-2-6

Ordering guide

CONTACT	D MAX	X MAX	PACKAGING
CLH-L2C	On ferrous materials: 3 mm On non-ferrous materials: 3 mm	2 mm	Sensor, magnet, spacer: 1 set